

# 37-50 & 37-60 Series V Bottom

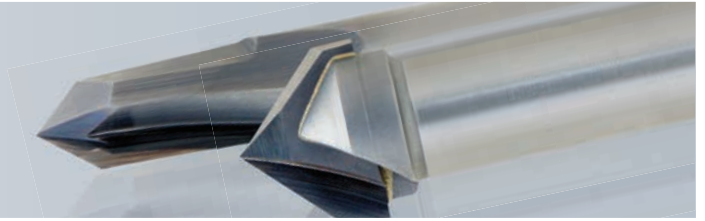

- SC
- CT
- 
- SW
- HW
- CW
- SP
- HP
- SSP
- LW

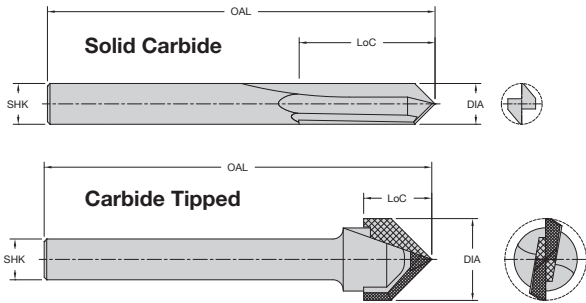

Designed for V grooving or beveling 90°.

37-50 Series Two Flute - V Bottom (Solid Carbide) Product Offering

Part Number	Cutting DIA (in)	LoC (in)	SHK DIA (in)	OAL (in)	Flutes
37-50	3/16	5/8	1/4	2	2
37-51	1/4	3/4	1/4	2	2
37-52	3/8	3/4	3/8	2-1/2	2

HELIX ANGLE ≈ 3° - 5° Shear

37-60 Series Two Flute - V Bottom (Carbide Tipped) Product Offering

Part Number	Cutting DIA (in)	LoC (in)	SHK DIA (in)	OAL (in)	Flutes
37-61	1/2	13/32	1/4	1-25/32	2
37-62	3/4	1/2	1/2	2-1/8	2
37-63	1	27/32	1/2	2-27/32	2

# 37-70 Series Folding Tool

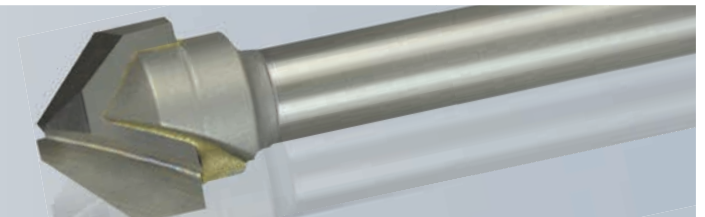

- CT
- 
- A

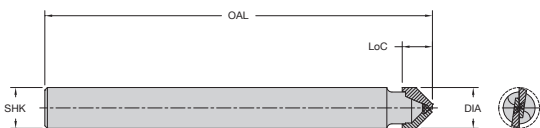

Designed for cutting aluminum/plastic sandwich materials with 90° angle and flat bottom.

90° angle and .090 flat for folding material



37-70 Series Two Flute - V Bottom (Carbide Tipped) Product Offering

Part Number	Cutting DIA (in)	LoC (in)	SHK DIA (in)	OAL (in)	Flutes
37-71	1/2	3/8	1/4	2	2
37-72	1/2	3/8	1/2	2	2